



## **Motores universales con carcasa de hierro fundido y aluminio**



UEM1041T

### **Motor de hierro fundido y aluminio**

- 50/60 Hz
- 1550 por minuto a 60 Hz
- Carcasa de hierro fundido completamente cerrado
- Puerto de aceite externo
- Funcionamiento a todo ángulo
- Listado por UL y CSA



UEM1091ALT

### **Carcasa de aluminio**

- 50/60 Hz
- 1550 por minuto a 60 Hz
- Carcasa de hierro fundido completamente cerrado
- Puerto de aceite externo
- Funcionamiento a todo ángulo
- Listado por UL y CSA

Consulte el reverso para ver el diagrama de la carcasa



### Carcasa de hierro fundido

Número de parte	Watts	Voltaje	UL	Referencia industrial	Rotación
UEM1021T	2W	115VAC	Si	5109	CW
UEM1025T	2.5W	115VAC	Si	5111	CW
UEM1041T	4W	115VAC	Si	5211	CW
UEM1061T	6W	115VAC	Si	5311	CW
UEM1091T	9W	115VAC	Si	5411	CW
UEM1161T	16W	115VAC	Si	5811	CW
UEM2091T	9W	230VAC	Si	5421	CW
UEM2161T	16W	230VAC	Si	5821	CW

Each motor furnished with hub washer, speed nut, neoprene silencer/vibration damper, and 3 mounting screws.

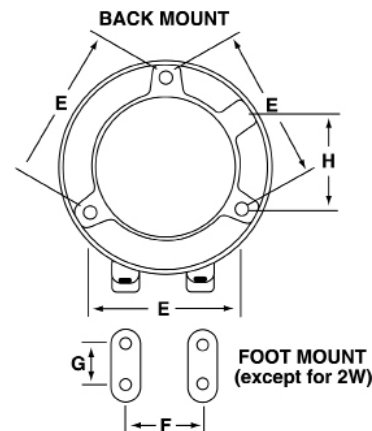
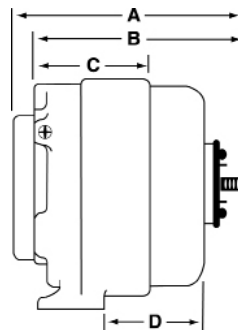

Motores de hierro fundido	A	B	C	D	E	F	G
2W	3.275	2.920	1.250		2.5		
2.5 & 4W	3.245	2.895	1.350	1.395	2.5	1.125	.625
6 & 9W	3.775	3.410	1.865	1.810	2.5	1.125	.625
16W	4.030	3.6655	1.862	2.09	2.5	1.125	.625

### Carcasa de aluminio

Número de parte	Watts	Voltaje	UL	Referencia industrial	Rotación
UEM1021ALT	2W	115VAC	Si	5109	CW
UEM1041ALT	4W	115VAC	Si	5213	CW
UEM1091ALT	9W	115VAC	Si	5413	CW

All motors sold in 12 lot quantities.

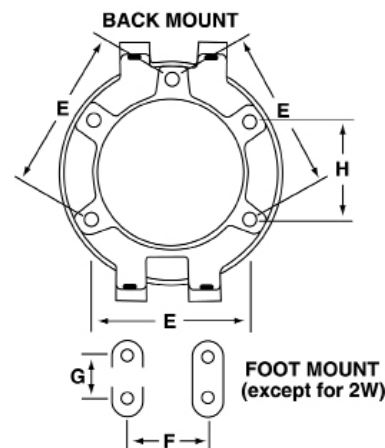
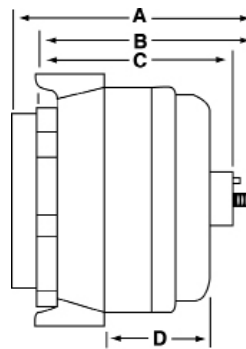

Motores de aluminio	A	B	C	D	E	F	G	H
2W					2.5			
4W	3.250	2.875	2.5	1.225	2.4	1.1225	.625	1.4
6 & 9W	3.525	3.150	2.80	1.475	2.4	1.125	.625	1.4

### Descargas



Ficha de Datos